

ARMSTRONG

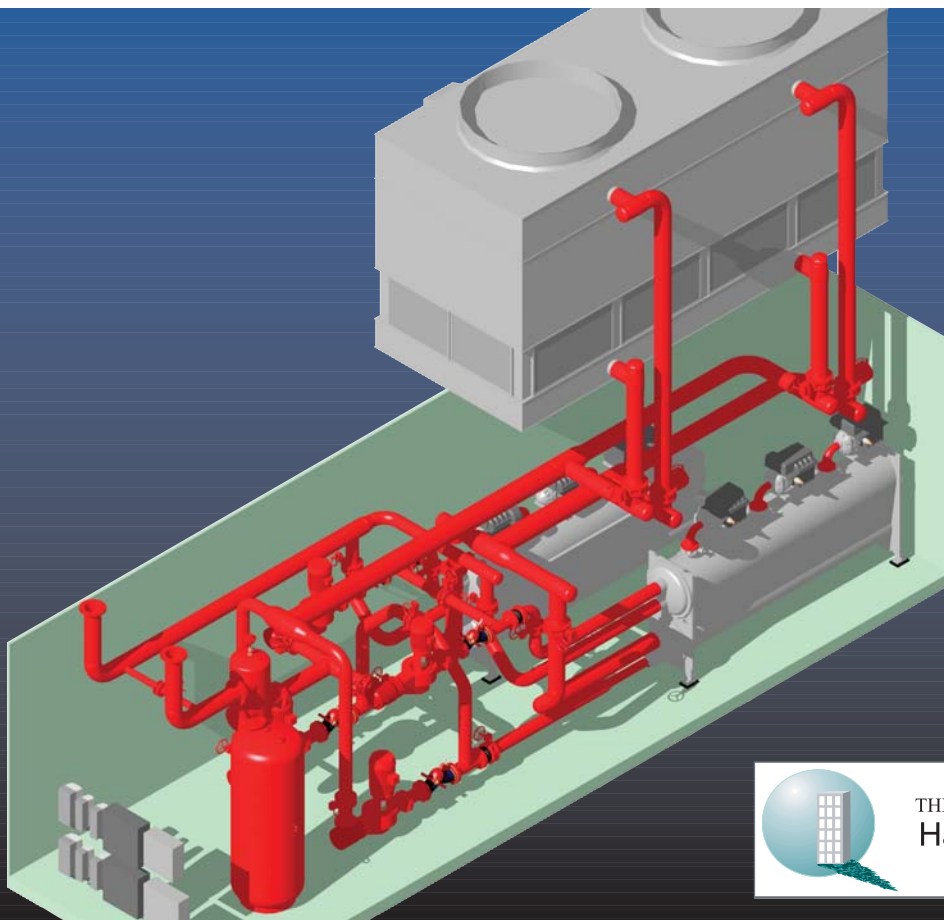

THIS PRODUCT EMPLOYS
Hartman LOOP®
TECHNOLOGIES

Ultra-Efficient Chilled Water Integrated Plant Package

FILE NO:	81.13
DATE:	Jan. 17, 2006
SUPERSEDES:	New
DATE:	New

Experience the risk-free approach to the most energy efficient chilled water plant solution.

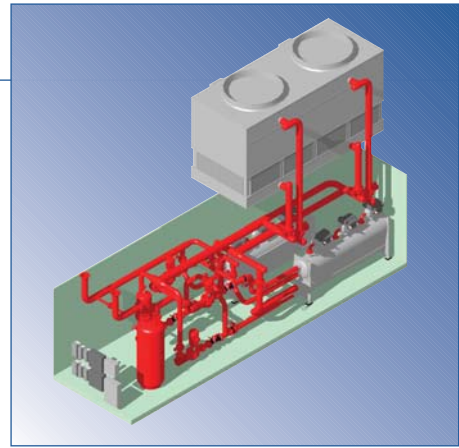

The Armstrong chilled water line of Integrated Plant Package (IPP-CHW) brings customers today's most space, energy and environmentally efficient solution for the 150 to 1080 ton at 60 Hz or 500 to 3600 kW at 50 Hz range.

Available for exterior installation with full enclosure or mechanical room installation, the IPP-CHW solution brings about a new way of constructing a facility.

The IPP-CHW solution is a pre-fabricated factory-built solution, optimized for quick installation with future service needs in mind.

All IPP-CHW solutions incorporate Armstrong VIL Series 4300 pumps, Turbocor™ oil-free frictionless compressors, and Armstrong IPC 11550 ultra-efficient chilled water plant control systems with Hartman LOOP® technology. This impressive combination provides important benefits for the end user including:

- ▶ Operating plant efficiencies of less than 0.5 kW/ton or COP of 7.3 (on an annual average basis)
- ▶ Remote monitoring and control functionality through the web for multi-facility operation
- ▶ The world's simplest pump seal replacement procedure
- ▶ Lubricant (oil) free compressor operation (saves on maintenance time and lubricant costs)
- ▶ Extremely quiet operation from the Turbocor™ (less than 75 dBA) compressor and the VIL pumps
- ▶ Extraordinarily low vibration levels from the VIL pumps and Turbocor™ compressor
- ▶ Easy access to components for compressor service, pump service and chiller tube bundle maintenance
- ▶ Best-in-class user interface for capturing operation data, or fine tuning system parameters through the IPC 11550 user interface screens

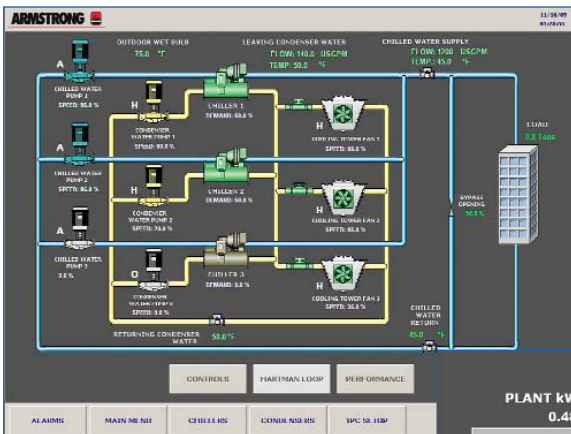

The IPP-CHW solution is available as a variable primary flow configuration or a variable primary/variable secondary configuration. Units can be configured to include an optional variable flow roof mounted cooling tower, or a cooling tower can be connected on-site separately.



Armstrong Chilled Water Integrated Plant Packages

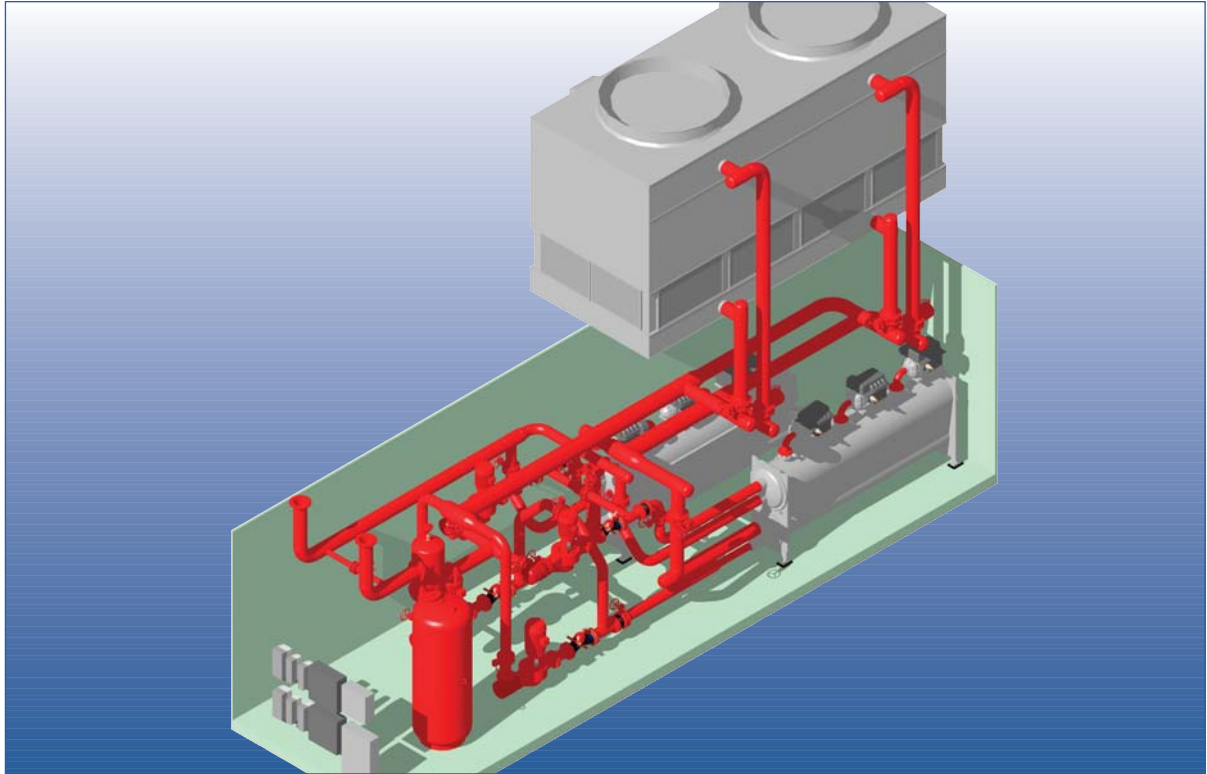

The IPP-CHW base plant is a complete operating plant built to local standards and includes:

- ▶ 2 centrifugal R134a chillers
- ▶ 2 primary and 2 condenser water pumps (2 secondary distribution pumps are optional)
- ▶ Standard pumps are split-coupled vertical in-line (VIL) Series 4300, optional dualArm Series 4302 are available for standby capacity
- ▶ Chiller and pump isolation butterfly-style valves
- ▶ Pump suction guides and flo-trex valves
- ▶ An optional insulated enclosure that includes refrigerant detection, appropriate code compliant ventilation, lighting, service access doors and insulated checkerplate floor
- ▶ An IPC 11550 Control System with Hartman LOOP® technology
- ▶ All necessary variable speed drives and electrical plant distribution
- ▶ Armstrong Vortex Air Separator or Dirt & Air Separator (DAS)
- ▶ All inter-connecting piping, elbows and isolation valves
- ▶ All chilled water piping is fully insulated with rugged PVC coating
- ▶ For coastal environments, optional PVC or stainless steel exterior piping to the cooling tower can be selected

The IPP-CHW base plants are shipped to site as one assembly for ratings up to 600 tons at 60 Hz or 2000 kW at 50 Hz, and shipped to site as 2 separate sections for for larger ratings. The optional cooling towers also arrive on a separate shipment.

Armstrong Integrated Plant Packages offer you a new business proposition for:

- ▶ Reducing project risk with delivery time, cost over runs, warranty call backs and integrated performance
- ▶ Growth opportunity by better leveraging your firms design and site resources
- ▶ Offering your customer a unique combination of technologically advanced hardware

► Typical Specifications - Chilled Water Plant Package

The chilled water mechanical plant shall be an all variable speed ultra-efficient prefabricated Armstrong IPP-CHW plant. The design day plant capacity shall be _____ tons (kW at 50 Hz) with a system design day delta T of _____ °F (°C). The design day wetbulb temperature is _____ °F (°C).

The equipment included in the IPP-CHW plant will be complete so as to enable provision of chilled water to the above defined design day building load by connection of the cooling tower, the CHW supply and return line, and one power connection of _____ V/60 Hz (V/50 Hz).

The system configuration shall be variable primary flow (with optional variable secondary distribution pumps). The load side system head loss outside of the plant is _____ ft. (m, kPa or psi).

The plant control sequence shall integrate Natural Curve optimization, the Equal Marginal Performance Principle, and Demand Based Control, as per the Hartman LOOP® methodology. The annual average plant efficiency shall be better than 0.5 kW/ton (COP of 7.3) including the cooling tower fan, condenser pump, chiller, and primary pump energy demand.

The enclosure (optional), shall include: Interior lighting, operational venting, emergency ventilation, refrigerant detection system, electrical outlets (3), service access doors to the chiller bundles and 2 person service access doors.

The chiller shall have lubricant-free, magnetic bearing Turbocor™ compressors with _____ standby compressors. The chiller shall have load turndown capacity of < 25% full rated load by way of compressor speed modulation without the additional effects of inlet guide vane adjustment.

Additional plant requirements include, but are not limited to:

- 2 centrifugal R134a chillers
- 2 primary and 2 condenser water pumps (2 secondary distribution pumps are optional)
- Standard pumps are split coupled vertical in-line (VIL) Series 4300, optional dualArm Series 4302 are available for standby capacity
- Chiller and pump isolation butterfly-style valves
- Pump Suction Guides and Flo-Trex Valves
- An optional insulated enclosure that includes refrigerant detection, appropriate code compliant ventilation, lighting, service access doors and insulated checkerplate floor
- An IPC 11550 Control System with Hartman LOOP® technology
- All necessary variable speed drives and electrical plant distribution
- Armstrong Vortex Air Separator
- All inter-connecting piping, elbows and isolation valves
- All chilled water piping is fully insulated with rugged PVC coating
- For coastal environments optional PVC or stainless steel exterior piping to the cooling tower

EXPERIENCE BUILDING...



S. A. Armstrong Limited
23 Bertrand Avenue
Toronto, Ontario
Canada, M1L 2P3
T: (416) 755-2291
F (Main): (416) 759-9101

Armstrong Pumps Inc.
93 East Avenue
North Tonawanda, New York
U.S.A., 14120-6594
T: (716) 693-8813
F: (716) 693-8970

Armstrong Integrated Systems Limited
Mucklow Hill
Halesowen, West Midlands
United Kingdom, B62 8DJ
T: +44 (0) 121 550 5333
F: +44 (0) 121 550 1679

Armstrong Holden Brooke Pullen
Wenlock Way
Manchester
United Kingdom, M12 5JL
T: +44 (0) 161 223 2223
F: +44 (0) 161 220 9660



© S.A. Armstrong Limited 2006

For further details, visit www.armstrongpumps.com or www.armstrongintegratedsystems.com